

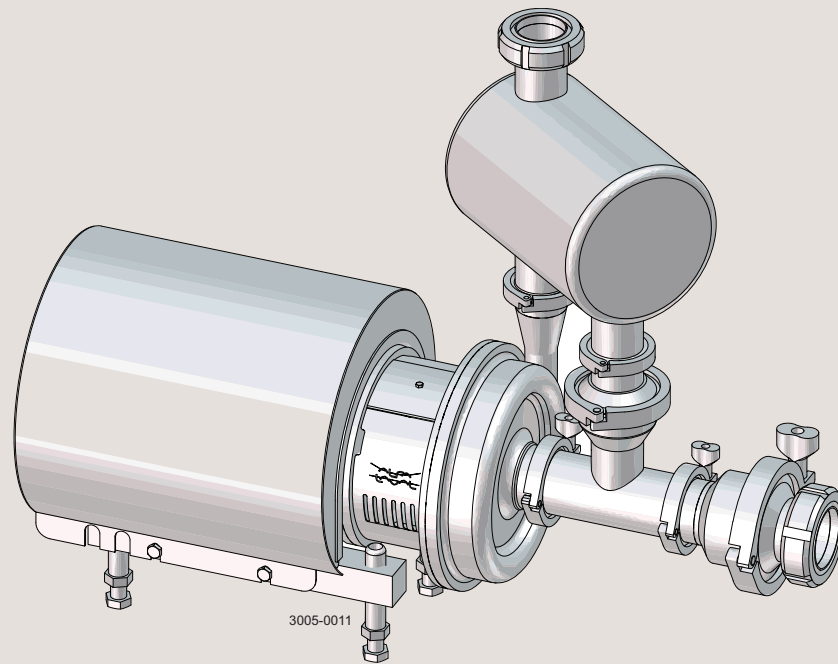

Instruction Manual

LKHSP Self-Priming Centrifugal Pump (Appendix)



NOTE!

This is an appendix to Operating Manual ESE00698 for LKH Centrifugal pump. This appendix must be used in connection with ESE00698 to ensure correct installation, operation and maintenance of the self-priming unit. Non-specified information is identical with the data for the standard LKH pump.

ESE02222-EN2 2015-08

Original manual

The information herein is correct at the time of issue but may be subject to change without prior notice

1. EC Declaration of Conformity	4
2. Description	5
2.1. Operation	5
2.2. Installation	5
2.3. Technical data	6
2.4. Working principle	7
3. Maintenance	8
3.1. Dismantling of self-priming unit	8
3.2. Assembly of self-priming unit	9
3.3. Weight (kg)	10
4. Parts list and service kits	12
4.1. LKHSP self-priming centrifugal pump	12

1 EC Declaration of Conformity

Revision of Declaration of Conformity 2009-12-29

The Designated Company

Alfa Laval Kolding A/S

Company Name

Albuen 31, DK-6000 Kolding, Denmark

Address

+45 79 32 22 00

Phone No.

hereby declare that

Pump

Designation

LKHSP-10, LKHSP-20, LKHSP-25, LKHSP-35, LKHSP-40

Type

From serial number 10.000 to 1.000.000

is in conformity with the following directive with amendments:

- Machinery Directive 2006/42/EC

The person authorised to compile the technical file is the signer of this document

QHSE Manager, Quality, Health and
safety & Environment

Title

Annie Dahl

Name

Kolding
Place

2013-12-03
Date



Signature



2.1 Operation

Step 1



Never run the pump with the pressure side blocked.

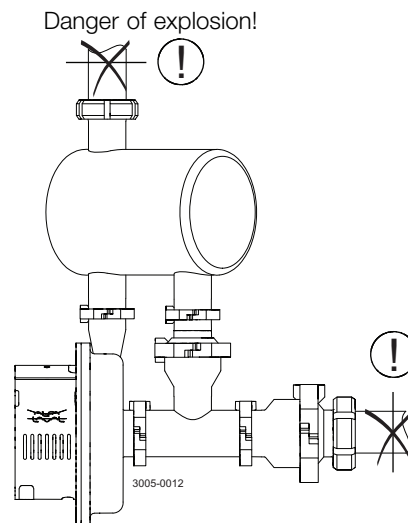

2.2 Installation

Step 1

At least 1 m (3.28 ft), and no more than 8 m (26.25 ft) of vertical pipe above the pump.

Max. static pressure at the outlet 80 kPa (0.8 bar) (11.6 psi)

NB! If higher, the LKC-2 (spec.) cannot work properly

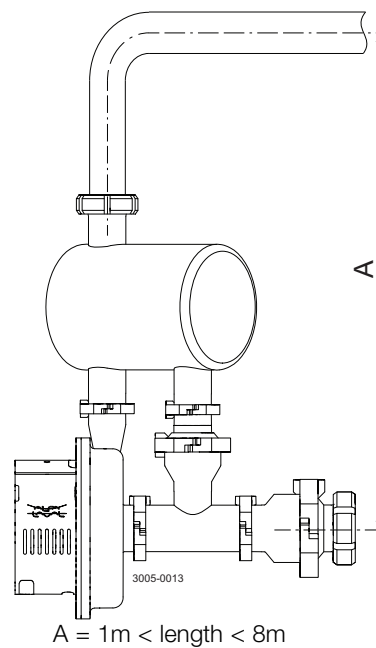

2 Description

2.3 Technical data

Pump data	
Max. inlet pressure:	1000 kPa (10 bar) (145 psi)
Temperature range:	-10°C to +100°C (14°F -284°F)
Noise level (at 1 m) (3.28 ft):	60 - 80 dB (A)
Max. static pressure at the outlet	80 kPa (0.8 bar) (11.6 psi)
NB! If higher, the LKC-2 (spec.) cannot work properly	
Max. speed	4000 rpm
Flushed seal	
Water pressure:	Normally atmospheric (max. 1 bar) (14.5 psi)
Water consumption:	0.25 -0.5 l/min (0.07-0.13 gpm)
Double mechanical seal	
Water pressure:	max. 5 bar (72.5 psi)
Water consumption:	0.25 -0.5 l/min (0.07-0.13 gpm)

2.4 Working principle

When the air or gas percentage exceeds 50-60%, the standard LKH pump can no longer uphold the liquid column and will therefore stop operating. With the self-priming unit fitted on the LKH centrifugal pump, it is possible to pump liquids containing air or gas as the pump will now operate as follows:

Normal operation:

During normal operation the NC non-return valve in the suction line is open due to the pressure difference over the valve. The pump raises the pressure level, and causes high pressure in the pressure line and also in the tank. The pressure in the tank ensures that the NO non-return valve in the return line is closed. Because of the valve, there is no bypass and therefore the pump has almost the same performance as a normal LKH pump.

Air in the suction line:

At some point, the pump stops pumping and the pressure difference over the NC non-return valve in the suction line disappears which means the valve closes. When the pump stops pumping, there is no longer a high pressure in the tank and the NO non-return valve in the return line will therefore open and make way for the product to flow into the tee and the pump casing. The pump starts circulating the product and creates a vacuum. When the vacuum is sufficiently high, the NC non-return valve in the suction line opens and the pump sucks a mixture of air and product. This continues until all air is evacuated and the pump starts pumping under normal conditions again.

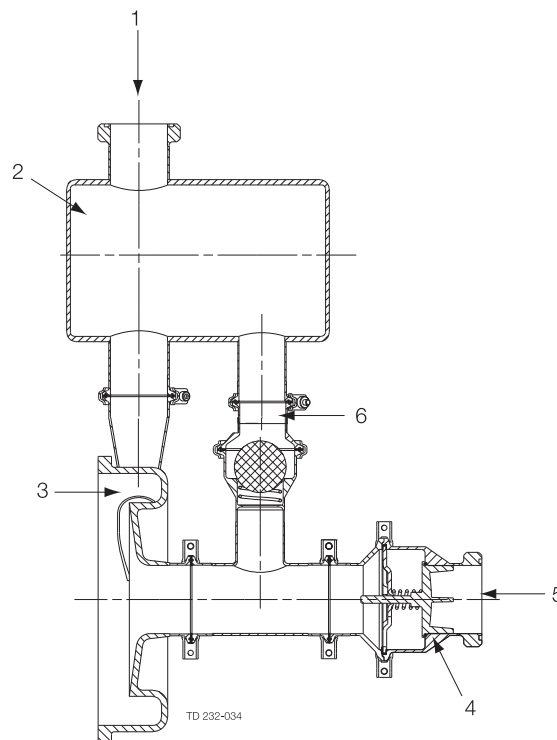

1. Pressure line
2. Tank
3. Pump casing on LKH pump
4. NC non-return valve
5. Suction line
6. Tee unit

3 Maintenance

Study the instructions carefully.

The items refer to the parts lists and service kits section.

Handle scrap correctly.

3.1 Dismantling of self-priming unit

Step 1

NOTE!

The self-priming unit consists of the following main parts:

- Tank
- NC non-return valve
- Tee with NO non-return valve is mounted on the pump casing on a standard LKH centrifugal pump, sizes -10, -20, -25, -35, -40. The dismantling instructions for the LKH pump can be seen in instruction manual ESE00698.

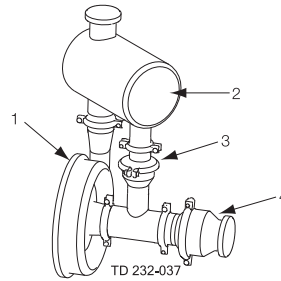

1. Pump casing on LKH-pump
2. Tank
3. Tee unit
4. NC non-return valve

Step 2

1. Unscrew clamp rings (73, 86) connecting tank (71) to the pump outlet and tee with NO non-return valve
2. Remove the tank.
3. Remove seal rings (72, 85).

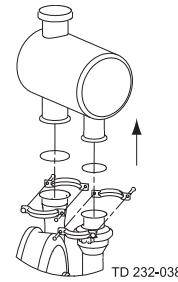

Step 3

1. Unscrew clamp ring (74) connecting the NC non-return valve and tee with NO non-return valve. 2. 3.
2. Remove the NC non-return valve.
3. Remove seal ring (75).

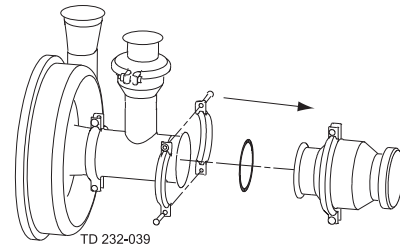

Step 4

1. Loosen and remove clamp ring (84).
2. Separate valve body (83), liner (77), valve cone (81), guide plate (79), seal ring (78), O-ring (82) and spring (80) as shown above.

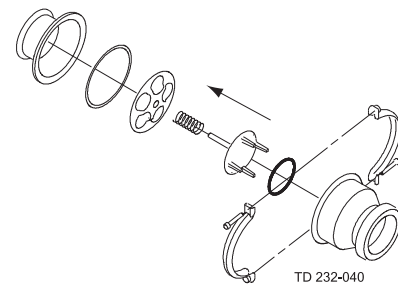

Step 5

1. Unscrew clamp ring (74) connecting the tee with NO non-return valve and pump inlet.
2. Remove the tee unit.
3. Remove seal ring (75).

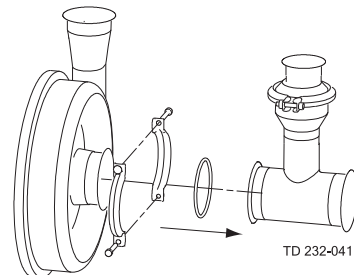

Study the instructions carefully.
The items refer to the parts lists and service kits section.
Handle scrap correctly.

Step 6

1. Loosen and remove clamp ring (91).
2. Separate ball (88), spring (89) and tee (76) as shown above.

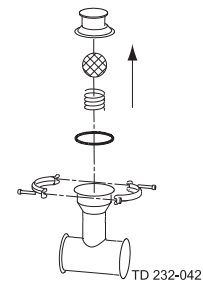

3.2 Assembly of self-priming unit

Step 1

NOTE!

The self-priming unit consists of the following main parts:

- Tank
- NC non-return valve
- Tee with NO non-return valve is mounted on the pump casing on a standard LKH centrifugal pump, sizes -10, -20, -25, -35, -40. The dismantling instructions for the LKH pump can be seen in instruction manual ESE00698.

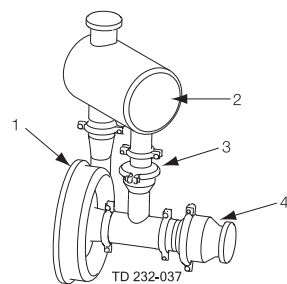

1. Pump casing on LKH-pump
2. Tank
3. Tee unit
4. NC non-return valve

Step 2

1. Fit ball (88), spring (89) and tee (76) together as shown above.
2. Fit and tighten clamp ring (91).

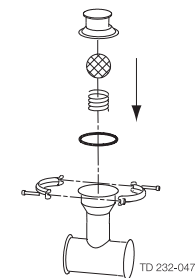

Step 3

1. Fit ball (88), spring (89) and tee (76) together as shown above.
2. Fit and tighten clamp ring (91).

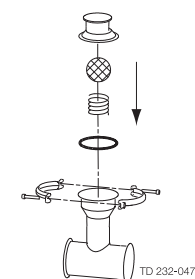

Step 4

1. Fit seal ring (75).
2. Fit and tighten clamp ring (74) connecting the tee with NO non-return valve and pump inlet.

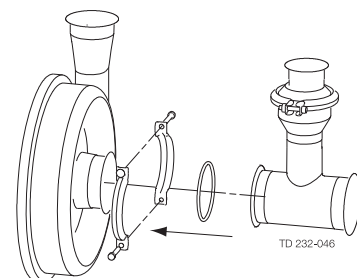

3 Maintenance

Study the instructions carefully.

The items refer to the parts lists and service kits section.

Handle scrap correctly.

Step 5

1. Fit valve body (83), liner (77), valve cone (81), guide plate (79), seal ring (78), O-ring (82) and spring (80) together as shown.
2. Fit and tighten clamp ring (84).

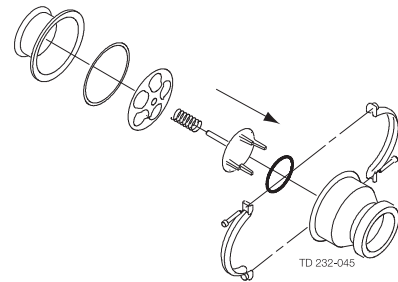

Step 6

1. Fit seal ring (75).
2. Fit the NC non-return valve.
3. Fit and tighten clamp ring (74) connecting the NC non-return valve and tee with NO non-return valve.

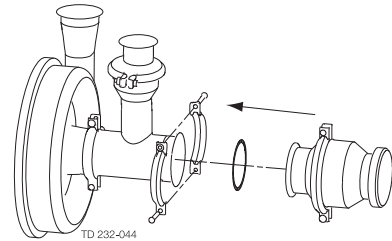

Step 7

1. Fit seal rings (2, 15).
2. Fit the tank on the NO non-return valve and the pump outlet. The welding liner (17) can be turned to fit the tank.
3. Fit and tighten clamp rings (3, 16) connecting tank (1) to the pump outlet and NO non-return valve.

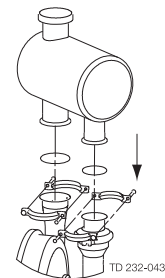

3.3 Weight (kg)

Pump Type: LKHSP

Size	90		100	112	132		160		180	
	1.5kW	2.2kW	3kW	4kW	5.5kW	7.5kW	11kW	15kW	18.5kW	22kW
10	63	65	80	85						
20	65	67	81	87	104	118				
25				92	109	123	183	197		
35				91	108	122	181	195		
40						126	186	200	218	236

Weight can vary depending of configuration. Weight is only to be seen as a reference value during handling, transporting and packaging.

4 Parts list and service kits

Study the instructions carefully.
The items refer to the parts lists and service kits section.
Handle scrap correctly.

4.1 LKHSP self-priming centrifugal pump

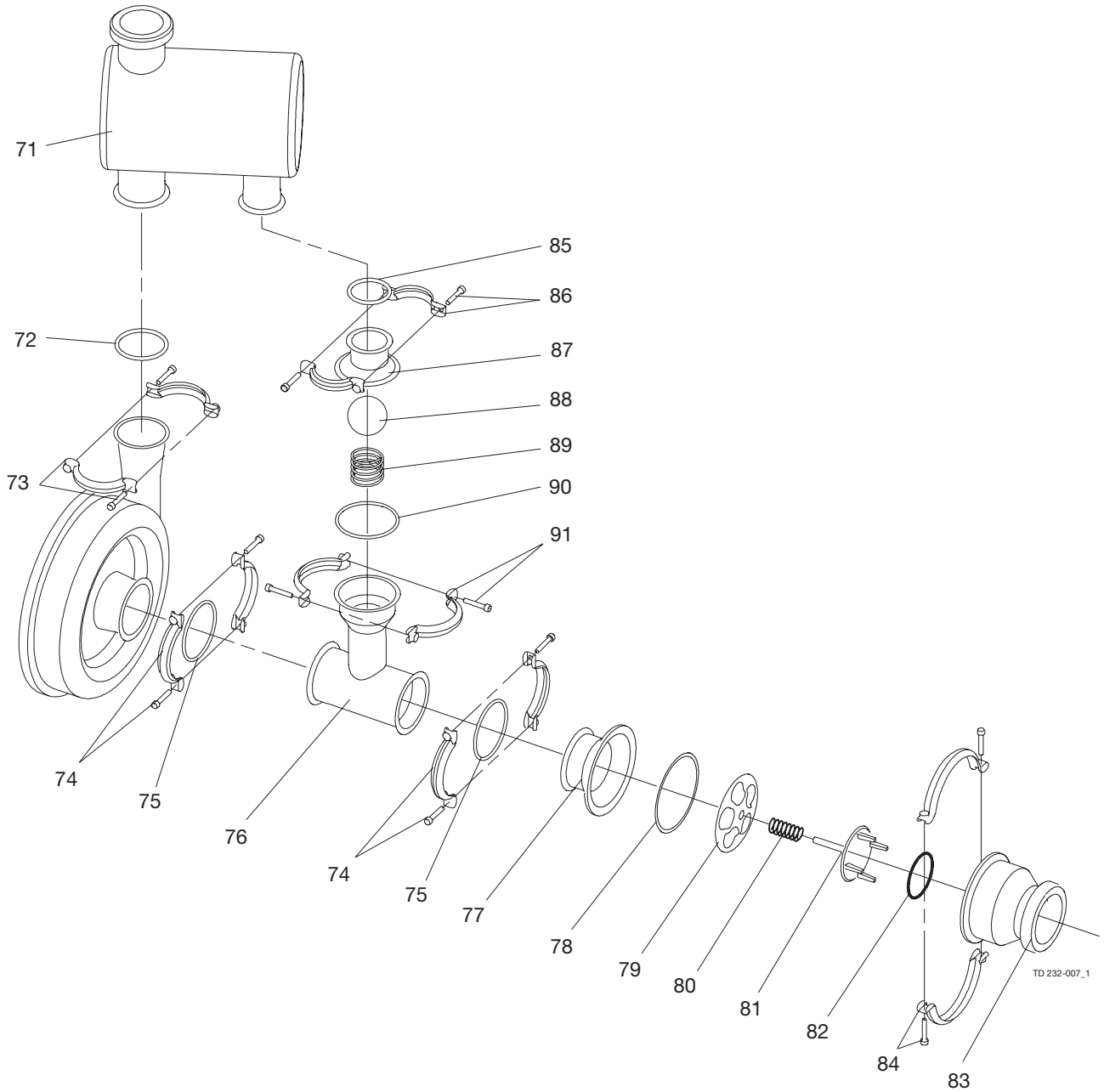

4 Parts list and service kits

Study the instructions carefully.
The items refer to the parts lists and service kits section.
Handle scrap correctly.

Parts list

Pos.	Qty	Denomination
71	1	Tank complete
72 <input type="checkbox"/>	1	Seal ring
73	1	Clamp ring complete
74	2	Clamp ring complete
75 <input type="checkbox"/>	2	Seal ring
76	1	Tee, ISO-clamp
77	1	Liner, ISO-clamp
78 <input type="checkbox"/>	1	Seal ring
79	1	Guide plate
80	1	Spring
81	1	Valve cone
82 <input type="checkbox"/>	1	O-ring
83	1	Valve body
84	1	Clamp ring complete
85 <input type="checkbox"/>	1	Seal ring
86	1	Clamp complete
88	1	Ball, PP
89	1	Spring
90 <input type="checkbox"/>	1	Seal ring
91	2	Clamp ring complete

Service kits

Denomination	LKHSP -10/ -20/, -35	LKHSP -25/ - 40
Service kit, EPDM	9611922248	9611922251
Service kit, NBR	9611922249	9611922252
Service kit, FPM	9611922250	9611922253

Parts marked with are included in the service kits.

Recommended spare parts: service kits.

(900025/3)

How to contact Alfa Laval

Contact details for all countries are continually updated on our website.

Please visit www.alfalaval.com to access the information directly.

© Alfa Laval Corporate AB

This document and its contents is owned by Alfa Laval Corporate AB and protected by laws governing intellectual property and thereto related rights. It is the responsibility of the user of this document to comply with all applicable intellectual property laws. Without limiting any rights related to this document, no part of this document may be copied, reproduced or transmitted in any form or by any means (electronic, mechanical, photocopying, recording, or otherwise), or for any purpose, without the expressed permission of Alfa Laval Corporate AB. Alfa Laval Corporate AB will enforce its rights related to this document to the fullest extent of the law, including the seeking of criminal prosecution.