

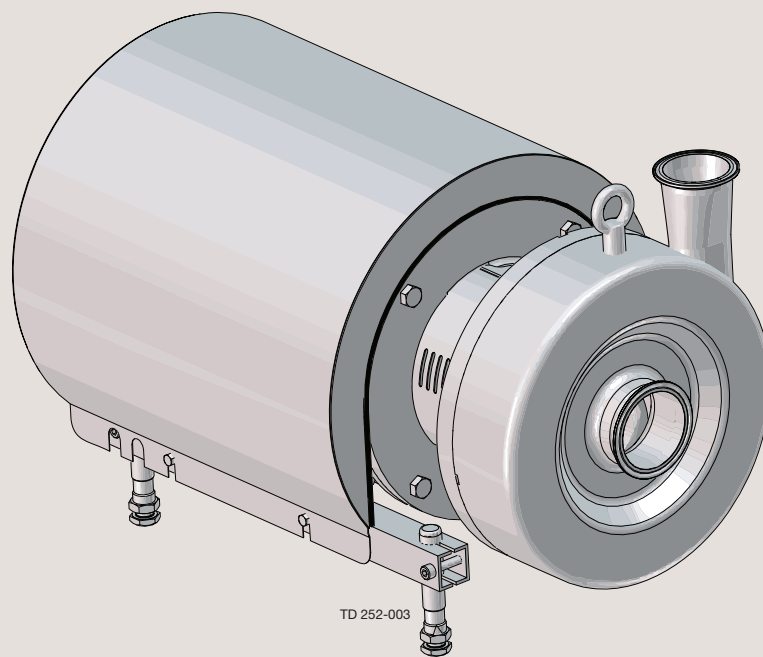

Instruction Manual

LKHPF Filtration Centrifugal Pump for High Inlet Pressure



ESE01950-EN10 2019-03

Original manual

The information herein is correct at the time of issue but may be subject to change without prior notice

1. EC Declaration of Conformity	4
2. Safety	5
2.1. Important information	5
2.2. Warning signs	5
2.3. Safety precautions	6
3. Installation	7
3.1. Unpacking/delivery	7
3.2. Installation	8
3.3. Pre-use check - pump without/with impeller screw	10
3.4. Recycling information	11
4. Operation	12
4.1. Operation/Control	12
4.2. Troubleshooting	14
4.3. Recommended cleaning	15
5. Maintenance	17
5.1. General maintenance	17
5.2. Cleaning procedure	18
5.3. Dismantling of pump/shaft seals	19
5.4. Assembly of pump/shaft seal	22
6. Technical data	25
6.1. Technical data	25
6.2. Torque specifications	26
6.3. Weight (kg)	26
6.4. Noise emission	27
6.5. Relubrication intervals	28
7. Parts list and service kits	30
7.1. LKHPF Filtration centrifugal pump for high inlet pressure	30
7.2. LKHPF - Wet end	31
7.3. LKHPF - Motor-dependent parts	33
7.4. LKHPF - Shaft seals	35

1 EC Declaration of Conformity

Revision of Declaration of Conformity 2009-12-29

The Designated Company

Alfa Laval Kolding A/S

Company Name

Albuen 31, DK-6000 Kolding, Denmark

Address

+45 79 32 22 00

Phone No.

hereby declare that

Pump

Designation

LKHPF-10, LKHPF-20, LKHPF-25, LKHPF-35, LKHPF-40, LKHPF-45, LKHPF-50, LKHPF-60, LKHPF-70

Type

From serial number 10.000 to 1.000.000

is in conformity with the following directive with amendments:

- Machinery Directive 2006/42/EC

The person authorised to compile the technical file is the signer of this document

Global Product Quality Manager
Pump, Valves, Fittings and Tank Equipment

Title

Lars Kruse Andersen

Name

Kolding
Place

2013-12-03
Date

Signature



*Unsafe practices and other important information are emphasised in this manual.
Warnings are indicated by means of special signs.
Always read the manual before using the pump!*

2.1 Important information

WARNING

Indicates that special procedures must be followed to avoid serious personal injury.

CAUTION

Indicates that special procedures must be followed to avoid damage to the pump.

NOTE

Indicates important information to simplify or clarify procedures.

2.2 Warning signs

General warning:



Dangerous electrical voltage:



Caustic agents:



2 Safety

All warnings in the manual are summarised on this page.

Pay special attention to the instructions below so that serious personal injury and/or damage to the pump are avoided.

2.3 Safety precautions

Installation:

Always read the technical data thoroughly. (See chapter 6 Technical data)

Always use a lifting crane when handling the pump.



Pump without impeller screw:

Always remove the impeller before checking the direction of rotation.

Never start the pump if the impeller is fitted and the pump casing is removed.

Pump with Impeller screw:

Never start in the wrong direction of rotation with liquid in the pump.

Always have the pump electrically connected by authorised personnel.



Always have the pump electrically connected by authorised personnel. (See the motor instructions)

Operation:

Always read the technical data thoroughly. (See chapter 6 Technical data)

Never touch the pump or the pipelines when pumping hot liquids or when sterilising.

Never run the pump with both the suction side and the pressure side blocked.

Never run the pump when partially installed or not completely assembled

Necessary precautions must be taken if leakage occurs as this can lead to hazardous situations.



Always handle lye and acid with great care.

Never use the pump for products not mentioned in the Alfa Laval pump selection program.

The Alfa Laval pump selection program can be acquired from your local Alfa Laval sales company.



Maintenance:

Always read the technical data thoroughly. (See chapter 6 Technical data)

Never service the pump when it is hot.

Never service the pump if pressurized.

Always use Alfa Laval genuine spare parts.



Motors with grease nipples:

Always lubricate according to motor manufactures recommended procedures.

Always locate and remove grease vent plugs, if provided, prior to adding grease.

Always check motor nameplate for grease type and lubrication intervals.

Always disconnect the power supply when servicing the pump.



Transportation:

Transportation of the pump or the pump unit:

Never lift or elevate the pump in any way other than as described in this manual

Always drain the pump head and accessories of any liquid

Always ensure that no leakage of lubricants can occur

Always transport the pump in its upright position

Always ensure that the unit is securely fixed during transportation

Always use original packaging or similar during transportation

3.1 Unpacking/delivery

Step 1

Always use a lifting crane when handling the pump (see technical data).

CAUTION

Alfa Laval cannot be held responsible for incorrect unpacking.

WARNING:

Be aware that certain pump configurations can tilt, and thereby cause injuries to feet or fingers. The pump should be supported underneath the adaptor, when not installed in the process line.

Check the delivery for:

1. Complete pump.
2. Delivery note.
3. Motor instructions.

Step 2

Remove any packing materials from the inlet and the outlet.
 Avoid damaging the inlet and the outlet.
 Avoid damaging the connections for flushing liquid, if supplied.

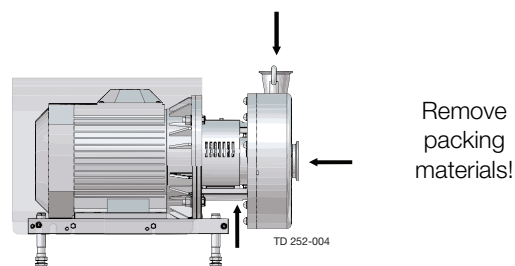

Step 3

Inspect the pump for visible transport damage.

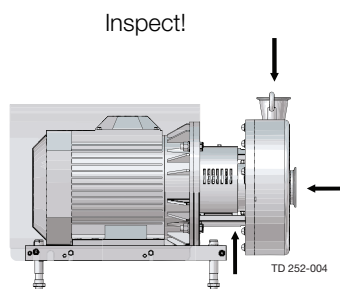

Step 4

Always remove the shroud, if fitted, before lifting the pump.

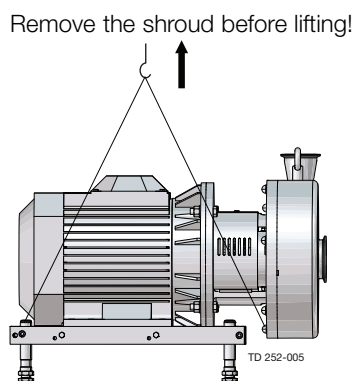

3 Installation

Read the instructions carefully and pay special attention to the warnings! Always check the pump before operation.
- See the pre-use check in section 3.3 Pre-use check - pump without/with impeller screw.
The larger pumps sizes are very heavy. Alfa Laval therefore recommends the use of a lifting crane when handling the pump.

3.2 Installation

Step 1



Always read the technical data thoroughly. (See chapter 6 Technical data)



Always use a lifting crane when handling the pump. (See chapter 6 Technical data)



Always have the pump electrically connected by authorised personnel. (see the motor instructions).

CAUTION

Alfa Laval cannot be held responsible for incorrect installation.

WARNING:

Alfa Laval recommends the installation of lockable repair breaker. If the repair breaker is to be used as an emergency stop, the colours of the repair breaker must be red and yellow.

Step 2

Ensure that there is sufficient clearance around the pump (min. 0.5 m) (1.64").

Caution:

The pump does not prevent back flow when intentionally or unintentionally stopped. If back flow can cause any hazardous situations, precautions must be taken e.g. a check valve is to be installed in the system preventing that described above.

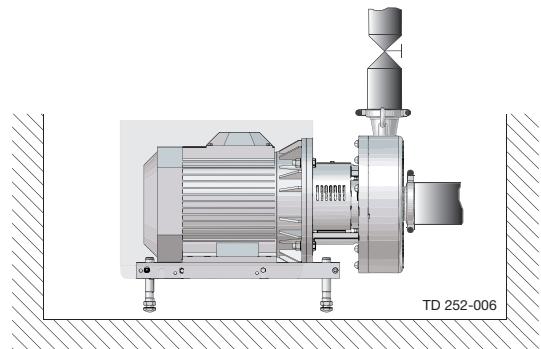

Step 3

Check that the flow direction is correct.

O: Outlet

I: Inlet

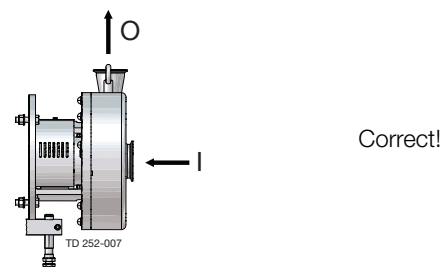

Step 4

1. Ensure that the pipelines are routed correctly.
2. Ensure that the connections are tight.

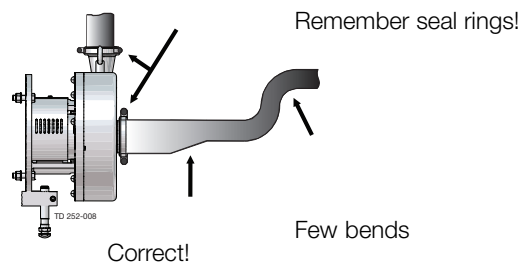

3 Installation

Read the instructions carefully and pay special attention to the warnings! Always check the pump before operation.

- See the pre-use check in section 3.3 Pre-use check - pump without/with impeller screw.

The larger pumps sizes are very heavy. Alfa Laval therefore recommends the use of a lifting crane when handling the pump.

Step 5

Avoid stress on the pump.

Piping system must be self-supported.

Pay special attention to:

- Vibrations.
- Thermal expansion of the tubes.
- Excessive welding.
- Overloading of the pipelines.

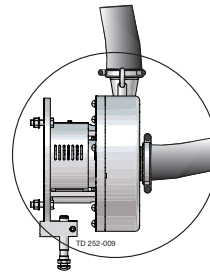

Note

In case of shaft seal leakage, the media will drip from the slot in the bottom of the adaptor. In case of shaft seal leakage, Alfa Laval recommends putting a drip tray underneath the slot for collecting the leakage.

3 Installation

Study the instructions carefully and pay special attention to the warnings!
 LKH-5 to LKH-60 are supplied without impeller screw as standard but this can be supplied.
 Check the direction of rotation of the impeller before operation.
 - See the indication label on the pump.

3.3 Pre-use check - pump without/with impeller screw

Step 1 Pump without impeller screw



Always remove the impeller before checking the direction of rotation.

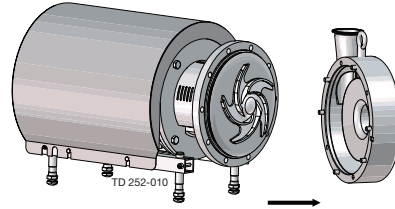

Never start the pump if the impeller is fitted and the pump casing is removed.

1. Remove cap nuts (28), washers (29) and pump casing (45).
2. Remove impeller (39) (see also the instruction in section 5.4 Assembly of pump/shaft seal).

Step 2

1. Start and stop the motor momentarily.
2. Ensure that the direction of rotation of the stub shaft (9) is anti-clockwise as viewed from the inlet side.

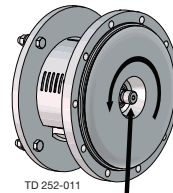

See the indication label!

Correct!

Stub shaft

Step 3

Fit and tighten impeller (39).

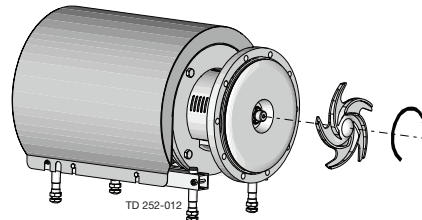

Step 4

1. Fit pump casing (45).
2. Fit washers (29) and cap nuts (28) and tighten.

Note: Cap nuts must be tightened according to the torque values specified in section 6 Technical data

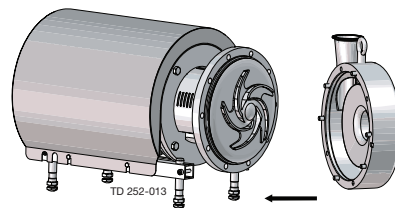

Step 1

Pump with impeller screw



Never start in the wrong direction of rotation with liquid in the pump.

1. Start and stop the motor momentarily.
2. Ensure that the direction of rotation of the motor fan is clockwise as viewed from the rear end of the motor.

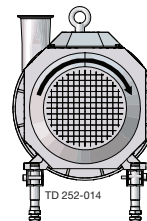

See the indication label!

Correct

View from rear end of motor

3.4 Recycling information

- **Unpacking**

- Packing material consists of wood, plastics, cardboard boxes and in some cases metal straps.
- Wood and cardboard boxes can be re-used, recycled or used for energy recovery.
- Plastics should be recycled or burnt at a licensed waste incineration plant.
- Metal straps should be sent for material recycling.

- **Maintenance**

- During maintenance, oil and wearing parts in the machine are replaced.
- All metal parts should be sent for material recycling.
- Worn out or defective electronic parts should be sent to a licensed handler for material recycling.
- Oil and all non-metal wearing parts must be disposed of in accordance with local regulations.

- **Scrapping**

- At the end of use, the equipment must be recycled according to the relevant, local regulations. Besides the equipment itself, any hazardous residues from the process liquid must be considered and disposed of in a proper manner. When in doubt, or in the absence of local regulations, please contact your local Alfa Laval sales company.
-

4 Operation

Read the instructions carefully and pay special attention to the warnings!

4.1 Operation/Control

Step 1



Always read the technical data thoroughly. See chapter 6 Technical data

CAUTION

Alfa Laval cannot be held responsible for incorrect operation/control.

Step 2



Never touch the pump or the pipelines when pumping hot liquids or when sterilising.

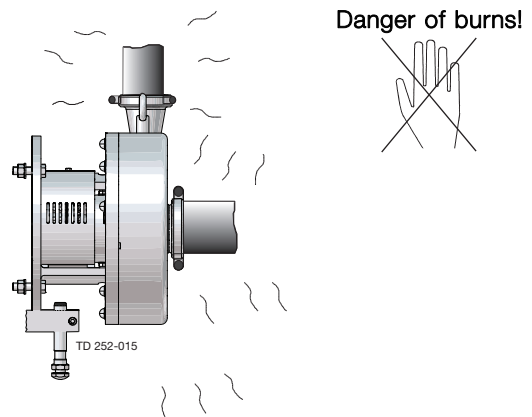

Step 3



Never run the pump with both the suction side and the pressure side blocked.

Danger of explosion!

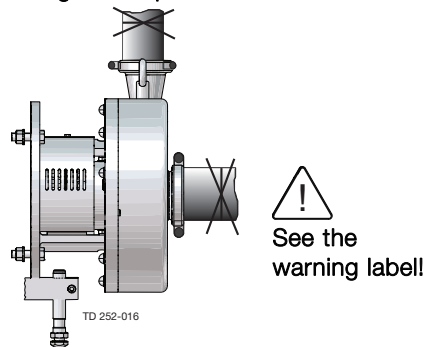

Step 4

CAUTION

The shaft seal must not run dry.

CAUTION

Never throttle the inlet side.

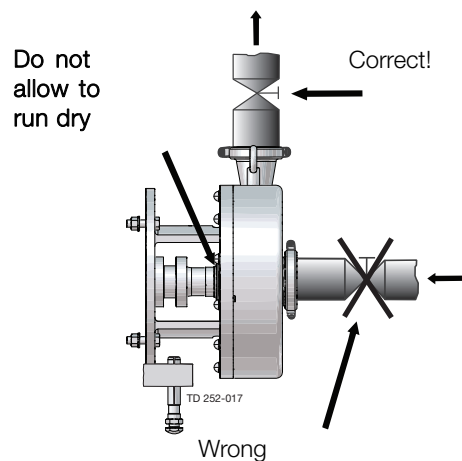

Read the instructions carefully and pay special attention to the warnings!

Step 5

Flushed shaft seal:

1. Connect the inlet of the flushing liquid correctly (ø6 tube).
2. Regulate the water supply correctly.
3. Observe the steam data.

O: Outlet
I: Inlet

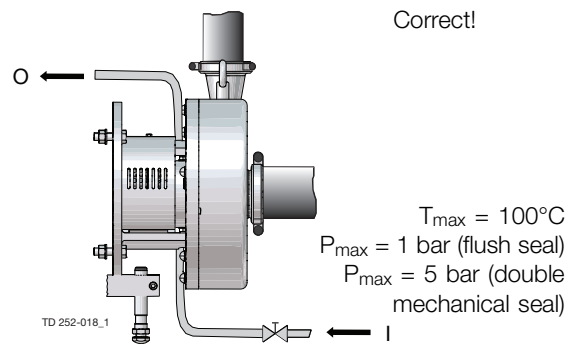

Step 6

Control:

Reduce the capacity and the power consumption by means of:

- Throttling the pressure side of the pump.
- Reducing the impeller diameter.
- Reducing the speed of the motor.

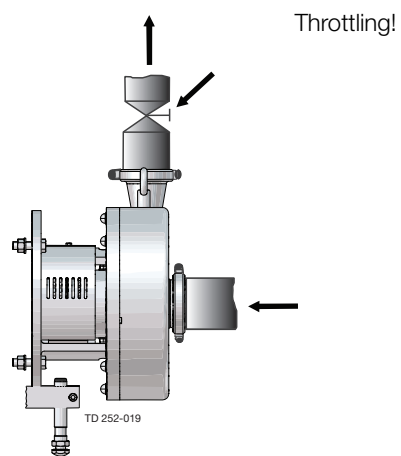

4 Operation

*Pay attention to possible faults.
Read the instructions carefully.*

4.2 Troubleshooting

NOTE!

Study the maintenance instructions carefully before replacing worn parts. - See section 5.1 General maintenance

Problem	Cause/result	Remedy
Overloaded motor	<ul style="list-style-type: none"> - Pumping of viscous liquids - Pumping of high density liquids - Low outlet pressure (counter pressure) - Lamination of precipitates from the liquid 	<ul style="list-style-type: none"> - Larger motor or smaller impeller - Higher counter pressure (throttling) - Frequent cleaning
Cavitation: <ul style="list-style-type: none"> - Damage - Pressure reduction (sometimes to zero) - Increase in noise level 	<ul style="list-style-type: none"> - Low inlet pressure - High liquid temperature 	<ul style="list-style-type: none"> - Increase the inlet pressure - Reduce the liquid temperature - Reduce the pressure drop before the pump - Reduce speed
Leaking shaft seal	<ul style="list-style-type: none"> - Dry run - Incorrect rubber grade - Abrasive particles in the liquid 	Replace: All wearing parts If necessary: <ul style="list-style-type: none"> - Change rubber grade - Select stationary and rotating seal ring in silicon carbide/silicon carbide
Leaking O-ring seals	Incorrect rubber grade	Change rubber grade

The pump is designed for cleaning in place (CIP). CIP = Cleaning In Place.
 Read the instructions carefully and pay special attention to the warnings!
 NaOH = Caustic soda.
 HNO₃ = Nitric acid.

4.3 Recommended cleaning

Step 1



Always handle lye and acid with great care.

Danger, caustic!



Always wear rubber gloves!



Always wear protective goggles!

Step 2



Never touch the pump or the pipelines when sterilising.

Danger of burns!

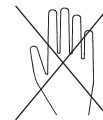
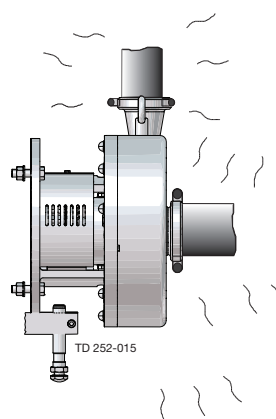

Step 3

Examples of cleaning agents: Use clean water, free from chlorides.

1. 1% by weight NaOH at 70°C (158°F).

1 kg (2.2 lb) NaOH	+	100 l (26.4 gal) water	= Cleaning agent.
-----------------------	---	---------------------------	-------------------

2.2 l (0.6 gal) 33% NaOH	+	100 l (26.4 gal) water	= Cleaning agent.
-----------------------------	---	---------------------------	-------------------

2. 0.5% by weight HNO₃ at 70°C (158°F).

0.7 l (0.2 gal) 53% HNO ₃	+	100 l (26.4 gal) water	= Cleaning agent.
---	---	---------------------------	-------------------

1. Avoid excessive concentration of the cleaning agent
 ⇒ Dose gradually!
2. Adjust the cleaning flow to the process.
 Sterilisation of milk/viscous liquids
 ⇒ Increase the cleaning flow!

4 Operation

The pump is designed for cleaning in place (CIP). CIP = Cleaning In Place.
Read the instructions carefully and pay special attention to the warnings!
NaOH = Caustic soda.
HNO₃ = Nitric acid.

Step 4



Always rinse well with clean water after using a cleaning agent.

NOTE

The cleaning agents must be stored/disposed of in accordance with current regulations/directives.

NOTE:

If pumps are sterilised using steam, standard 3A requires the process system to be designed to automatically shut down if the product pressure in the system becomes less than that of the atmosphere and it cannot be started until the system is re-sterilised.

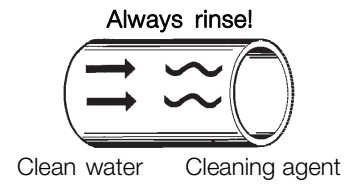

Maintain the pump carefully. Read the instructions carefully and pay special attention to the warnings!
 Always keep spare shaft seals and rubber seals in stock.
 See separate motor instructions.
 Check the pump for smooth operation after service.

5.1 General maintenance

Step 1



Always read the technical data thoroughly. (See chapter 6 Technical data)



Always disconnect the power supply when servicing the pump.

NOTE

All scrap must be stored/discharged in accordance with current rules/directives.

Step 2



Never service the pump when it is hot.

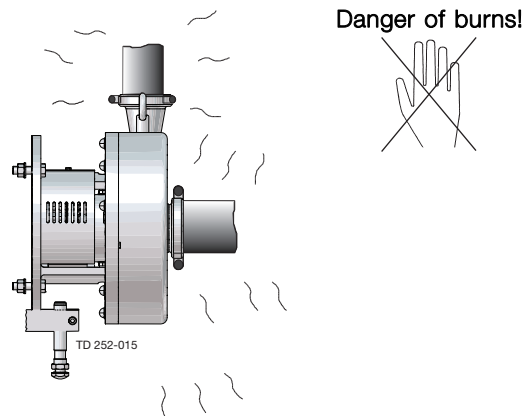

Step 3



Never service the pump with the pump and pipelines under pressure.

CAUTION

Fit the electrical connections correctly if they have been removed from the motor during service. (see 3.3 Pre-use check - pump without/with impeller screw)

CAUTION

Pay special attention to the warnings!

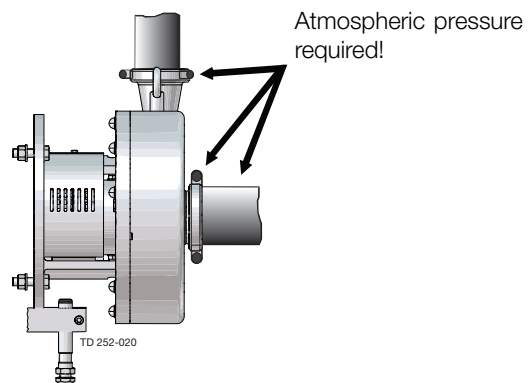

Step 4

Recommended spare parts:

Order service kits from the service kits list (see chapter 7 Parts list and service kits).

Ordering spare parts

Contact your local Alfa Laval sales company.

Note:

If the pump is supplied with FEP O-rings, Alfa Laval recommends replacing the casing O-ring during pump maintenance.

5 Maintenance

Maintain the pump carefully. Read the instructions carefully and pay special attention to the warnings!
 Always keep spare shaft seals and rubber seals in stock.
 See separate motor instructions.
 Check the pump for smooth operation after service.

NOTE! Read the maintenance instructions carefully before replacing worn parts. - See section 5.1 General maintenance

	Shaft seal	Rubber seals	Motor bearings
Preventive maintenance	Replace after 12 months: (one-shift) Complete shaft seal	Replace when replacing the shaft seal	
Maintenance after leakage (leakage normally starts slowly)	Replace at the end of the day: Complete shaft seal	Replace when replacing the shaft seal	
Planned maintenance	<ul style="list-style-type: none"> - Regular inspection for leakage and smooth operation - Keep a record for the pump - Use the statistics for inspection planning purposes <p>Replace after leakage: Complete shaft seal</p>	Replace when replacing the shaft seal	Annual inspection is recommended <ul style="list-style-type: none"> - Replace complete bearing if worn - Ensure that the bearing is axially locked (See motor instructions)
Lubrication	Before fitting Lubricate the O-rings with silicone grease or silicone oil	Before fitting Silicone grease or silicone oil	See section 6.5 Relubrication intervals

Pre-use check

CAUTION!

Fit the electrical connections correctly if they have been removed from the motor during service. (See 3.3 Pre-use check - pump without/with impeller screw).

Pay special attention to warnings!

1. Start and stop the motor momentarily
2. Ensure that the pump operates smoothly.

5.2 Cleaning procedure

Cleaning procedure for soiled impeller screw tapped hole:

1. Remove stub shaft (9) in accordance with section 5.3 of the Service manual.
2. Submerge and soak the stub shaft for 5 minutes in COP tank with 2% caustic wash
3. Scrub the blind tapped impeller screw hole vigorously by plunging a clean 1/2" diameter sanitary bristle pipe brush in and out of the hole for two minutes while submerged.
4. Soak Stub Shaft (9) in acid sanitiser for 5 minutes, then scrub the blind tapped hole as described in step 3 above.
5. Rinse well with clean water and blow-dry the blind tapped hole with clean air.
6. Swab test the inside of the tapped hole to determine cleanliness.
7. Should the swab test fail, repeat steps 2 to 6 above until the swab test is passed.

Should swab testing continue to fail, or time is of the essence, install a new (spare) stub shaft (9).

Read the instructions carefully. The items refer to the parts list and service kits section.
 Handle scrap correctly.
 * : Relates to the shaft seal.

5.3 Dismantling of pump/shaft seals

Step 1

1. Unscrew cap nuts (28) and remove washers (29) and pump casing (45).

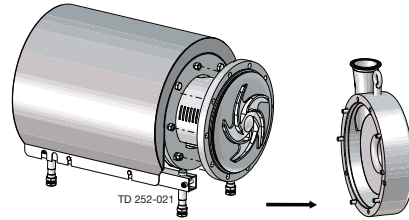

Step 2

Remove screw (14) and safety guard (15).

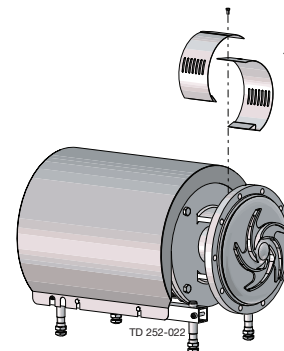

Step 3

Flushed shaft seal:

Unscrew fittings (23) using a spanner.

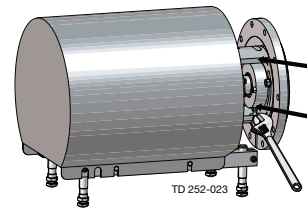

Step 4

1. Remove impeller screw (41), if fitted, and pull off O-ring (42).
 2. Remove impeller (39/40). If necessary, loosen the impeller by knocking gently on the impeller vanes.

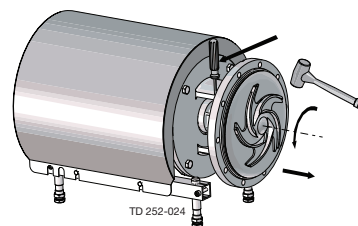

Counterhold with a screwdriver!

If necessary!

Step 5

Pull out impeller (39/40) and the rotating part of the shaft seal.

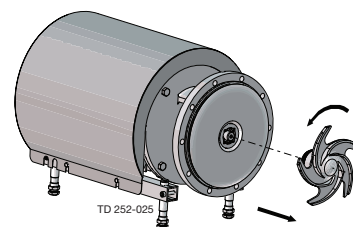

Step 6

Remove space ring (33) and the rotating part of the shaft seal from impeller (39)/(40).

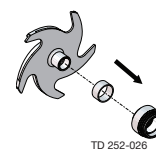

*

5 Maintenance

Read the instructions carefully. The items refer to the parts list and service kits section.

Handle scrap correctly.

* : Relates to the shaft seal.

Step 7

Separate rotating seal ring (34), quad rings (35, 38), support ring (36), guide ring (37) and washer (37) from rotating seal housing (37).

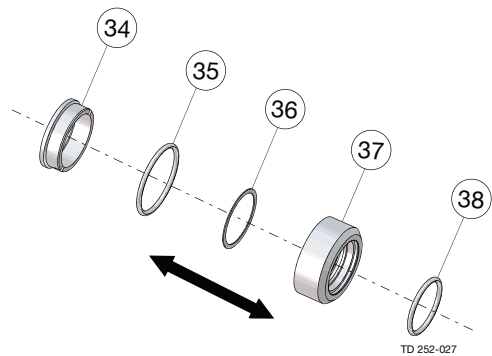

*

Step 8

1. Unscrew nuts (19) and remove washers (20) and back plate (30).
2. Pull off joint ring (43) from the back plate.

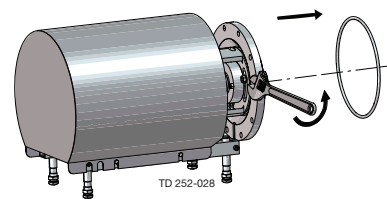

*

Step 9

1. Pull out stationary seal ring (32).
2. Remove O-ring (31) from the stationary seal ring.

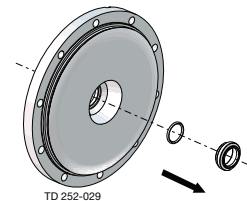

*

Step 10

Flushed shaft seal

1. Remove screws (22) and seal housing (21).
2. Pull out lip seal (24) and O-ring (26) from the seal housing.
3. Slide off sleeve (27) from stub shaft (9).
4. Remove O-ring (25) from the sleeve.

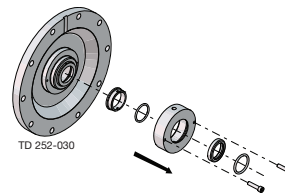

*

Step 11

1. Remove shroud (2).
2. Unscrew nuts (7) and remove washers (6), screws (18) and adaptor (17).

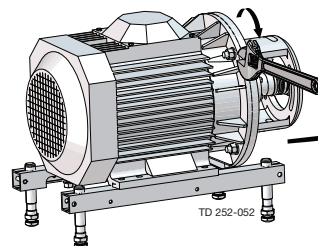

*

Step 12

1. Loosen screws (13).
2. Slide off stub shaft (9) together with compression rings (12a+b).

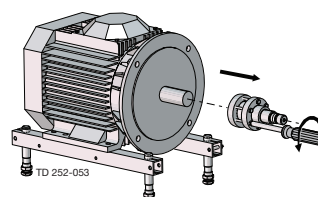

*

Read the instructions carefully. The items refer to the parts list and service kits section.
Handle scrap correctly.
* : Relates to the shaft seal.

Step 13
Separate screws (13), washers (13a) and compression rings (12a+b).

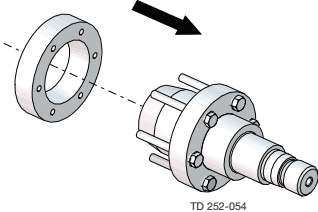

*

5 Maintenance

Read the instructions carefully. The items refer to the parts list and service kits section.

Handle scrap correctly.

* : Relates to the shaft seal.

5.4 Assembly of pump/shaft seal

Step 1

LKHPF-70

For securing the best fixture to the motor shaft, ensure the following:

- Conical surfaces on the pump shaft and compression rings are applied with grease.
- No grease on the motor shaft.
- No grease on the inside diameter of the pump shaft.
- Screws for the compression rings are applied with grease.

1. Fit compression rings (12a, 12b), washers (13a) and screws (13) on stub shaft (9).
2. Slide the stub shaft onto the motor shaft.
3. Check the clearance between the end of the stub shaft and the motor flange (10-20 mm) (0.39" - 0.78").

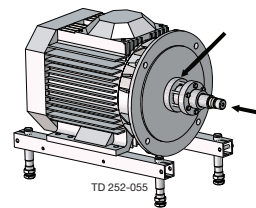

Step 2

1. Tighten screws (13) lightly and evenly.
2. Ensure that stub shaft (9) can be moved on the motor shaft.

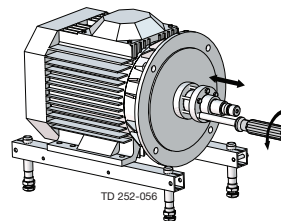

Step 3

Fit adaptor (17), screws (18), washers (6) and nuts (7) and tighten.

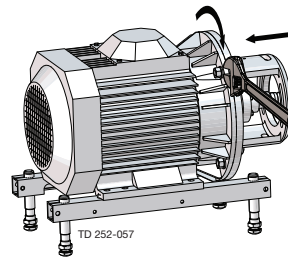

Step 4

Fit back plate (30), washers (20) and nuts (19) and tighten.
Tightening torques: See addendum.

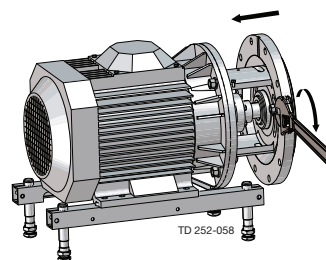

Step 5

Assemble the rotating part of the shaft seal as shown above.

CAUTION!

Ensure that the driver in the rotating seal housing enters the notch in the rotating seal ring.

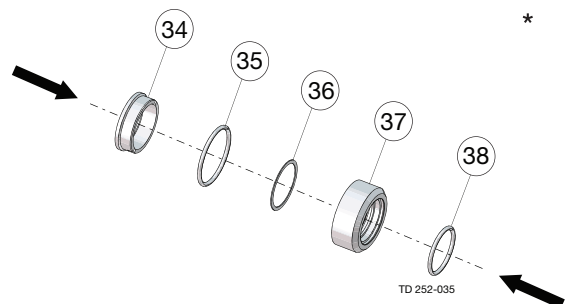

Read the instructions carefully. The items refer to the parts list and service kits section.

Handle scrap correctly.

* : Relates to the shaft seal.

Step 6

Fit the rotating part of the shaft seal and space ring (33) on impeller (39/40).

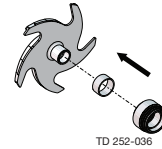

*

Step 7

1. Fit impeller (39) or (40) on stub shaft (9) by rotating clockwise.
2. Ensure that the clearance between the impeller and back plate (30) is 1.0 mm (0.04"). The clearance can be adjusted by knocking gently with a plastic hammer.

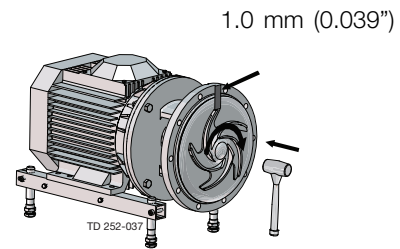

*

Step 8

1. Remove impeller (39) and back plate (30).
2. Tighten screws (13) evenly to 15 Nm (11.06 lbf-ft).

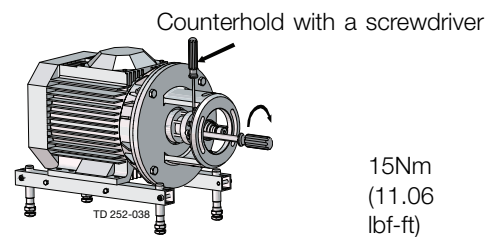

Step 9

1. Slide O-ring (31) onto stationary seal ring (32).
2. Press the stationary seal ring into back plate (30).

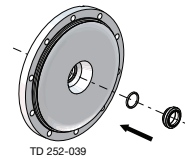

*

CAUTION!

Ensure the two notch in the stationary seal ring enters into the two pins in the backplate.

Step 10

Flushed shaft seal:

1. Fit lip seal (24) and O-ring (26) in seal housing (21).
2. Fit the housing on back plate (30) and tighten the screws (22).
3. Slide sleeve (27) with O-ring (25) onto stub shaft (9).

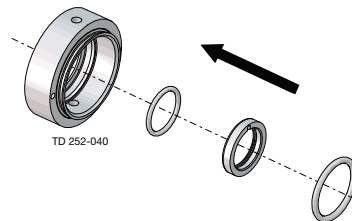

*

Step 11

1. Fit back plate (30), washers (20) and nuts (19) and tighten. Tightening torques: See 6 Technical data
2. Fit O-ring (43) on the back plate.

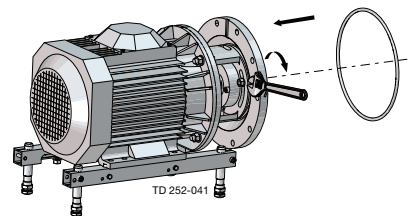

*

Step 12

1. Lubricate impeller hub (39) with silicone grease or oil.
 2. Screw the impeller onto stub shaft (9).
 3. If used, fit O-ring (42) and impeller screw (41).
- Tightening torque for impeller screw: 20 Nm (7.4 lbf-ft)

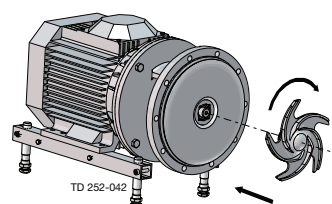

*

5 Maintenance

Read the instructions carefully. The items refer to the parts list and service kits section.

Handle scrap correctly.

* : Relates to the shaft seal.

Step 13

Flushed shaft seal

1. Screw fittings (23) into seal housing (21).
2. Tighten with a spanner.

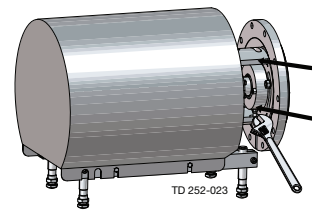

Step 14

1. Fit pump casing (45).
2. Fit washers (29) and cap nuts (28) and tighten.

Note: Cap nuts must be tightened according to the torque values specified in chapter 6 Technical data

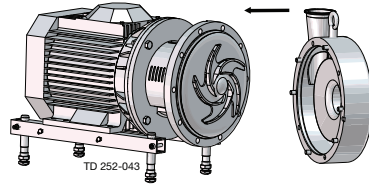

Step 15

1. Mount shroud (2).
 2. Position safety guard (15) and screw (14) and tighten.
- If the pump is not supplied with flush connections, the holes in the adaptor must be covered by the guard.

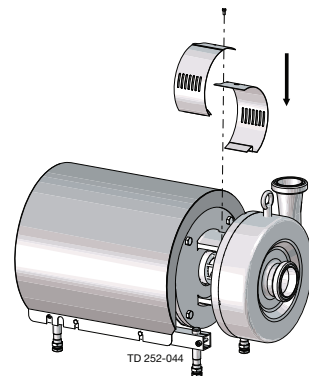

*It is important to observe the technical data during installation, operation and maintenance.
Inform personnel about the technical data.*

6.1 Technical data

The LKHPF is a highly efficient and economical centrifugal pump, specially designed for high inlet pressure e.g. for use in filtration systems. The LKHPF pump meets the requirements of sanitary and gentle product treatment and chemical resistance, and is available in the following sizes, LKHPF-10, -20, -25, -35, -40, -45, -50, -60, -70. Read the instructions carefully. The larger pumps sizes are very heavy. Alfa Laval therefore recommends the use of a lifting crane when handling the pump.

Data			
Max. inlet pressure	4000 kPa	(40 bar)	
Max. inlet pressure (USA)	600 psi		
Temperature range	-10°C to +140°C	(14 to 284°F)	(EPDM)
Max. speed	4000 rpm		
Maximum product viscosity	800 cP		
Materials			
Product wetted steel parts	AISI 316L		
Other steel parts	Stainless steel		
Finish	Semi-bright		
Product wetted seals	EPDM (standard)		
Other O-rings	EPDM		
Alternative seals	Nitrile (NBR), Fluorinated rubber (FPM)		
Shaft seal			
Seal types	Single internal, flushed seal		
Max. temperature flush media	70°C		
Max. water pressure (flushed seal)	Normally atmospheric (max. 1 bar) (max. 14.5 psi)		
Water consumption (flushed seal)	0.25 - 0.5 l/min. (0.06-0.13 gl)		
Material, stationary seal ring	Silicon carbide		
Material, rotating seal ring	Silicon carbide		
Material, Quad/O-rings	EPDM (standard)		
Alternative material, O-rings	Nitrile (NBR) and fluorinated rubber (FPM)		
Motor			
IEC LKHPF			
Standard foot-flanged motor according to IEC metric standard 2 poles = 3000/3600 rpm at 50/60 Hz IP55 (drain hole with labyrinth plug), insulation class F.			
Motor sizes (kW), 50 Hz	1.5 - 75 kW		
Motor sizes (kW), 60 Hz	1.75 - 86 kW		
Nema LKHPF			
For LKHPF-10 to -70: Standard foot-flanged motor according to NEMA standard. 2 pole = 3600 rpm at 60 Hz.			
Motor sizes (Hp), 60 Hz	7.5 - 100 Hp		

For further information, see PD sheet.

6 Technical data

*It is important to observe the technical data during installation, operation and maintenance.
Inform personnel about the technical data.*

6.2 Torque specifications

The table below specifies the tightening torques for the screws, bolts and nuts in this pump.

Always use the torques specified below if no other values are stated. This can be a matter of personal safety.

Size	Tightening torque	
	Nm	lbf-ft
M8	20	15
M10	40	30
M12	67	49
M14	110	81

6.3 Weight (kg)

Pump Type: LKHPPF

Size	90		112		132		160		180		200		250	
	2.2kW	4kW	5.5kW	7.5kW	11kW	15kW	18.5kW	22kW	30kW	37kW	45kW	55kW	75kW	
10	64	84												
20	68	88	105	119										
25		101	118	132	191	205								
35		101	119	133	192	206								
40				132	192	206	224	242						
45		103	120	134	194	208								
50			118	132	191	205	223	242						
60			120	134	193	207	225	244	352					
70			156	170	214	228	246	277	384	399	415	541	576	

Weight can vary depending of configuration. Weight is only to be seen as a reference value during handling, transporting and packaging.

*It is important to observe the technical data during installation, operation and maintenance.
Inform personnel about the technical data.*

6.4 Noise emission

Pump Type	Sound pressure level (dBA)
LKH-5	60
LKH-10	69
LKH-15	72
LKH-20	70
LKH-25	74
LKH-35	71
LKH-40	75
LKH-45	70
LKH-50	75
LKH-60	77
LKH-70	88
LKH-75	79
LKH-85	86
LKH-90	75
LKH-112	70
LKH-113	69
LKH-114	68
LKH-122	75
LKH-123	77
LKH-124	80
SolidC-1	68
SolidC-2	72
SolidC-3	73
SolidC-4	72
MR-166	76
MR-185	82
MR-200	81
MR-300	82
GM	54
FM-OS	61

The above LKH noise levels are the same for LKHPPF, LKHI, LKH UltraPure, LKH Evap and LKHHex.
The above SolidC noise levels are the same for SolidC UltraPure.

The noise measurements have been carried out with the original motor and shroud, at the approximate Best Efficiency Point (BEP), with the water at ambient temperature and at 50 Hz.

Very often the noise level generated by the flow through the process system (e.g. valves, pipes, tanks etc.) is much higher than that generated by the pump itself. Therefore, it is important to consider the noise levels of the whole system and take the necessary precautions with regard to personal safety, if required.

6 Technical data

Relubrication interval 50 Hz (3000 rpm)/Relubrication interval 60 Hz (3600 rpm). (Vendor) quantity in Drive End/quantity in Non Drive End.

6.5 Relubrication intervals

The table is for an internal bearing temperature of 100°C. An increase in temperature of 15°C (ambient or internal in bearings), will reduce the greasing interval and bearing lifetime by 50%. The lubrication interval for vertically mounted pumps is half the value stated in the table.

ABB IEC motors, IE3

Motor power (kW)	LKH5 -90 LKH110 -60* LKH-110* LKHSP LKH UltraPure 50/60 Hz	LKHPF-10 -60 LKH1-10 -60 LKH-110 3300 Bearing 50/60 Hz	LKHPF-70 LKH-120 7200 Bearing 50/60 Hz	LKH-85 7300 Bearing 50/60 Hz
0.75	Permanently lubricated			
1.1	Permanently lubricated			
1.5	Permanently lubricated	Not available		
2.2	Permanently lubricated	Permanently lubricated		
3.0	Permanently lubricated	Not available		
4.0	Permanently lubricated	Permanently lubricated		
5.5	Permanently lubricated	3600h/3000h - DE/NDE:15g*		
7.5	Permanently lubricated	3600h/3000h - DE/NDE:15g*		
11	Permanently lubricated	3100h/2300h - DE/NDE:25g		
15	Permanently lubricated	3100h/2300h - DE/NDE:25g		
18.5	Permanently lubricated	3100h/2300h - DE/NDE:25g		
22	Permanently lubricated	2600h/2000h - DE/NDE:42g	4000h/2200h - DE/NDE:42g	
30	Permanently lubricated		4000h/2800h - DE/NDE:55g	8000h/ - - DE/NDE:40g
37	Permanently lubricated		4000h/2800h - DE/NDE:55g	8000h/ - - DE/NDE:40g
45	Permanently lubricated		2500h/1000h - DE/NDE:55g	8000h/ - - DE/NDE:40g
55	Permanently lubricated		2500h/1000h - DE/NDE:73g	8000h/3000h - DE/NDE:60g
75	Permanently lubricated		1500h/500h - DE/NDE:73g	4000h/1500h - DE/NDE:60g
90				4000h/2800h - DE/NDE:45g
110				4000h/2800h - DE/NDE:45g

* inlet pressure less than 10 bar (145 psi)

Recommended grease types:

LKHPF-10/-70 – LKH-110 - LKH-120:

Esso: Unirex N2 or N3 (Lithium complex base)
 Mobil: Mobilith SHC 100 (Lithium complex base)
 Shell: Shell Gadus S5 V100 2 (Lithium complex base)
 Klüber: Klüberplex BEM 41-132 (Special Lithium base)
 FAG: Arcanol TEMP110 (Lithium complex base)
 Lubcon: Turmogrease L 802 EP PLUS (Lithium complex base)

*LKHPF-10/-60 – LKH-110

Klüber: Klüber Asonic HQ72-102 (Polyurea base)

LKH-85:

Klüber: Klüberplex Quiet BQH 72-102 (Polyurea base)
 Lubcon: Turmogrease PU703 (Polyurea base)

WARNING: Polyurea-based grease must not be mixed with Lithium complex base grease and vice versa.

6 Technical data

Relubrication interval 50 Hz (3000 rpm)/Relubrication interval 60 Hz (3600 rpm). (Vendor) quantity in Drive End/quantity in Non Drive End.

Table 1. Sterling Nema motors

Motor RPM	Frame VS. HP	Type of service Standard 8 hrs/day	Heavy duty 24 hrs/day
3600	143T - 286TS 1.5 - 30	*	*
	324TS - 455TS 40 - 150	6 Months	2 Months
1800	143T - 256T 1 - 20	*	*
	284T - 326T 25 - 50	4 Months	18 Months
	364T - 445T 60 - 150	9 Months	3 Months
1200	143T - 256T 0.75 - 10	*	*
	284T - 326T 15 - 30	4 Years	18 Months
	364T - 445T 40 - 125	1 Year	4 Months

* Motors of this size normally do not have bearings that can be re-lubricated.

These bearings should be replaced at least every 5 years for 8 hr/day service, or every 2 years for 24 hr/day service.

Warning: Bearing grease is Klüber NBU-15 - DO NOT SUBSTITUTE!

7 Parts list and service kits

The drawing shows the LKHPF pump.
The items refer to the parts lists in the following sections

7.1 LKHPF Filtration centrifugal pump for high inlet pressure

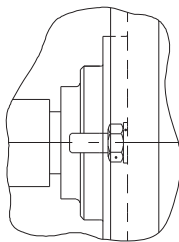
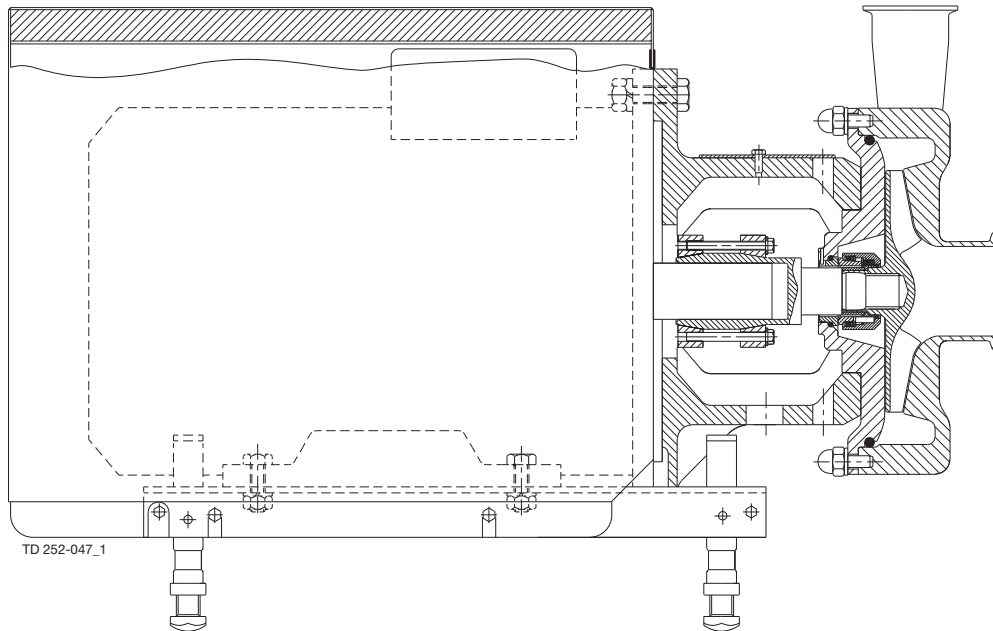

TD 252-048_1
Mounting of back plate to adaptor

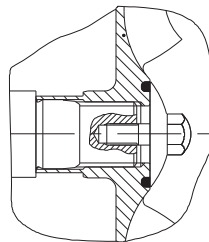

TD 252-050_1
Impeller screw

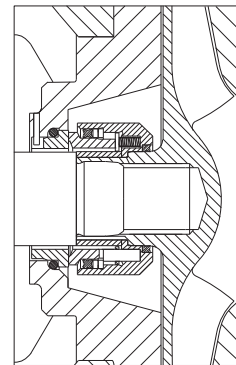

TD 252-062
Single shaft seal

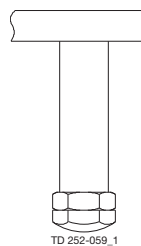

TD 252-059_1
Mounting of legs
55-75 kW

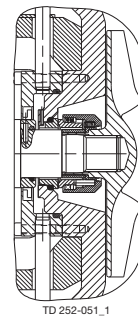

TD 252-051_1
Flushed shaft seal

The drawing shows the LKHPF pump.
The items refer to the parts lists in the following sections

7.2 LKHPF - Wet end

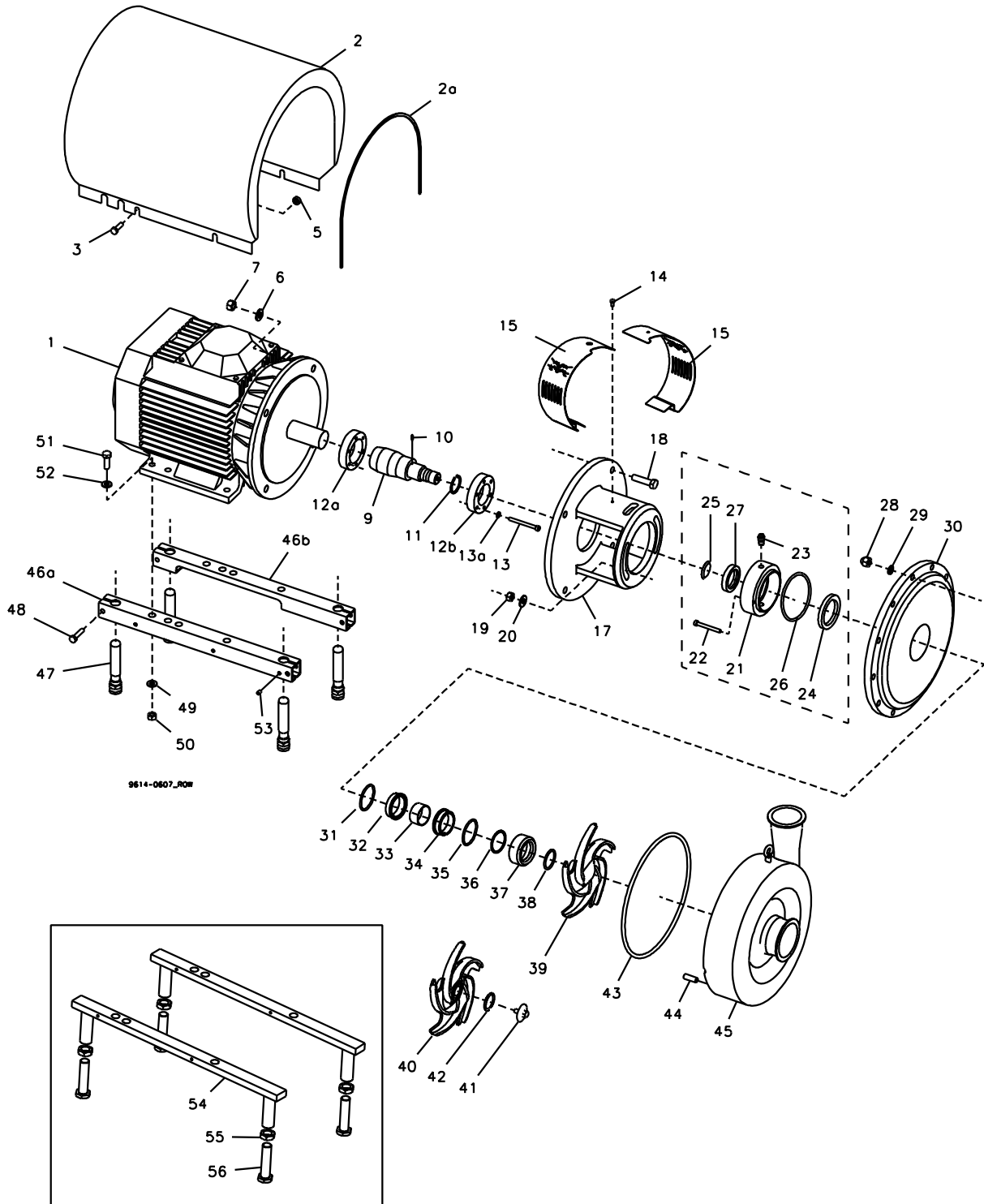

7 Parts list and service kits

The drawing shows the LKHPF pump.

The items refer to the parts lists in the following sections

Parts list

Pos.	Qty	Denomination
19	2	Nut
20	2	Washer
28	10	Cap nut
29	10	Washer
30	1	Back plate
39	1	Impeller
40	1	Impeller for impeller screw
41	1	Impeller screw
42 ♦♦	1	O-ring
43 □♦○★	1	O-ring
44	10	Bolt
45	1	Pump casing compl.

The drawing shows the LKHPF pump.
The items refer to the parts lists in the following sections

7.3 LKHPF - Motor-dependent parts

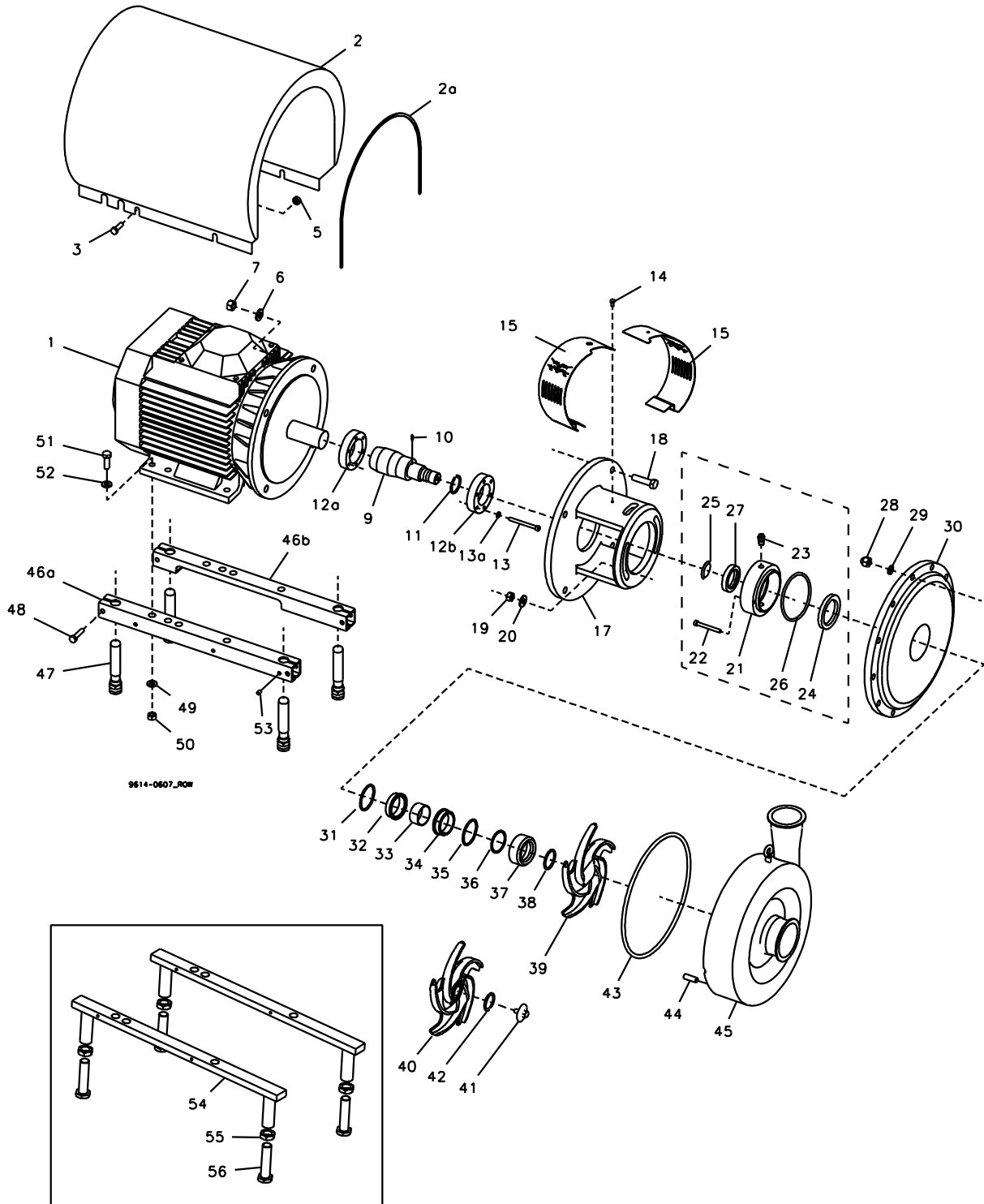

7 Parts list and service kits

The drawing shows the LKHPF pump.

The items refer to the parts lists in the following sections

Parts list

Pos.	Qty	Denomination
1	1	Motor ABB
2	1	Shroud
3	4	Screw
5	4	Distance sleeve
6	4	Washer for adaptor
7	4	Nut for adaptor
9	1	Shaft incl. pin
10	1	Connex pin
11	1	Retaining ring
12a	1	Compression ring with thread
12b	1	Compression ring without thread
13	6	Screw
13a	6	Washer
14	1	Screw for safety guard
15	1	Safety guard set
17	1	Adaptor
18	4	Screw for adaptor
46a	1	Support bar
46b	1	Support bar
47	4	Leg
48	4	Screw
49	4	Spring washer
50	4	Nut
51	4	Screw
52	4	Washer
53	4	Pivot screw
54	2	Leg bracket
55	4	Nut for leg
56	4	Screw for leg

The drawing shows the LKHPF pump.
The items refer to the parts lists in the following sections

7.4 LKHPF - Shaft seals

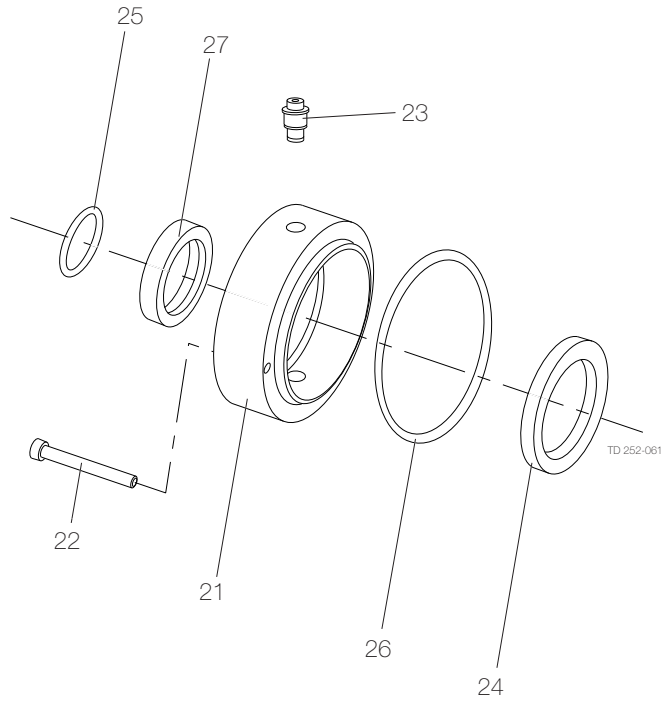

7 Parts list and service kits

The drawing shows the LKHPF pump.

The items refer to the parts lists in the following sections

Parts list

Pos.	Qty	Denomination
□♦		Shaft seal complete
○*		Shaft seal complete
21	1	Seal housing for flushed seal
22	2	Screw
23	2	Fittings
24	1	Lip seal
25	1	O-ring
26	1	O-ring
27	1	Sleeve
31	1	O-ring
32	1	Stationary seal ring
33	1	Spacing ring
34	1	Rotating seal ring
35	1	Quad ring/O-ring
36	1	PTFE support ring
37	1	Rotating seal housing
38	1	Quad ring/O-ring
57	1	Set of 8 springs for rotating sealhousing
	1	Set of 14 springs for rotating sealhousing

Service kits

Denomination	EPDM	NBR	FPM
Service kit for single shaft seal SiC/SiC			
□ Service kit, SiC/SiC (LKHPF -10)	9611922139	9611922140	9611922141
□ Service kit, SiC/SiC (LKHPF -20)	9611922151	9611922152	9611922153
□ Service kit, SiC/SiC (LKHPF -25/35/45)	9611922194	9611922195	9611922196
□ Service kit, SiC/SiC (LKHPF -40/50/60)	9611922163	9611922164	9611922165
Service kit for single shaft seal and impeller screw SiC/SiC			
♦ Service kit, SiC/SiC (LKHPF -10)	9611922142	9611922143	9611922144
♦ Service kit, SiC/SiC (LKHPF -20)	9611922154	9611922155	9611922156
♦ Service kit, SiC/SiC (LKHPF -25/35/45)	9611922197	9611922198	9611922199
♦ Service kit, SiC/SiC (LKHPF -40/50/60)	9611922166	9611922167	9611922168
♦ Service kit, SiC/SiC (LKHPF -70)	9611922946	9611922947	9611922948
Service kit for flushed shaft seal SiC/SiC			
○ Service kit, SiC/SiC (LKHPF -10)	9611922145	9611922146	9611922147
○ Service kit, SiC/SiC (LKHPF -20)	9611922157	9611922158	9611922159
○ Service kit, SiC/SiC (LKHPF -25/35/45)	9611922200	9611922201	9611922202
○ Service kit, SiC/SiC (LKHPF -40/50/60)	9611922169	9611922170	9611922171
Service kit for flushed shaft seal and impeller screw SiC/SiC			
* Service kit, SiC/SiC (LKHPF -10)	9611922148	9611922149	9611922150
* Service kit, SiC/SiC (LKHPF -20)	9611922160	9611922161	9611922162
* Service kit, SiC/SiC (LKHPF -25/35/45)	9611922203	9611922204	9611922205
* Service kit, SiC/SiC (LKHPF -40/50/60)	9611922172	9611922173	9611922174
* Service kit, SiC/SiC (LKHPF -70)	9611922949	9611922950	9611922951

Parts marked with □♦○* are included in the service kits. Recommended spare parts: Service kits.

Conversion single to flushed shaft seal : Please order Flushed service kit + pos. 21+22+23+27

(900599/10)

How to contact Alfa Laval

Contact details for all countries are continually updated on our website.

Please visit www.alfalaval.com to access the information directly.

© Alfa Laval Corporate AB

This document and its contents is owned by Alfa Laval Corporate AB and protected by laws governing intellectual property and thereto related rights. It is the responsibility of the user of this document to comply with all applicable intellectual property laws. Without limiting any rights related to this document, no part of this document may be copied, reproduced or transmitted in any form or by any means (electronic, mechanical, photocopying, recording, or otherwise), or for any purpose, without the expressed permission of Alfa Laval Corporate AB. Alfa Laval Corporate AB will enforce its rights related to this document to the fullest extent of the law, including the seeking of criminal prosecution.